



Vacuum Pumps & Stations

Electric Powered Mini-Vacuum Stations

132 00 387 • Revision B

Control Number: 113005 • Supersedes 132 00 199

ANVER EP1001 Series of Mini-Vacuum Stations

These low cost, compact electric-powered vacuum stations require little maintenance. A vacuum check valve is provided to maintain vacuum in case of power failure. On clean, smooth, non-porous material, the unit will hold vacuum per ASME Standard B30.20a-2001 for Vacuum Lifting Devices allowing the operator to put down the load safely. A vacuum attach/release valve is included to ensure a consistent attach/release.

Features a quality ANVER electric vacuum pump and a vacuum gauge to monitor vacuum level. Continuously running vacuum pump makes this vacuum station perform well on slightly porous material. An internal vacuum filter with replaceable element protects against contamination.

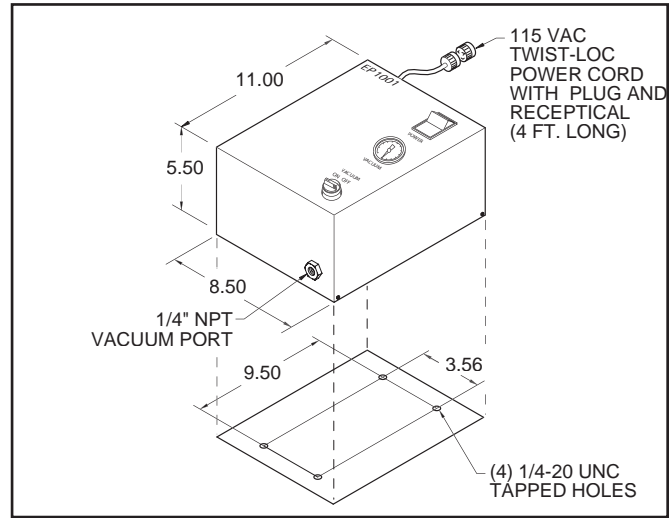

Specifications:

Model Number	Vacuum Pump No.	Supply Voltage	Vacuum Flow SCFM (l/min.)	Max. Vacuum in. Hg (mm Hg)	Weight lbs. (kg)
EP1001	PMP-085-115	115-60-1 (2.5 Amps)	0.85 (24.12)	24 (610)	16 (7)