

Vacuum Cup Suspension Assemblies



Rigid Cup and Slides with Side Vacuum Port



Rigid Suspension Assemblies are also available for our medium sized vacuum cups. Double spring suspensions and side vacuum ports make these assemblies perfect for virtually any material handling application. Adjustable slides are available in a variety of sizes making it easy to adapt to any system. Designed for Medium VC Series Vacuum Cups.

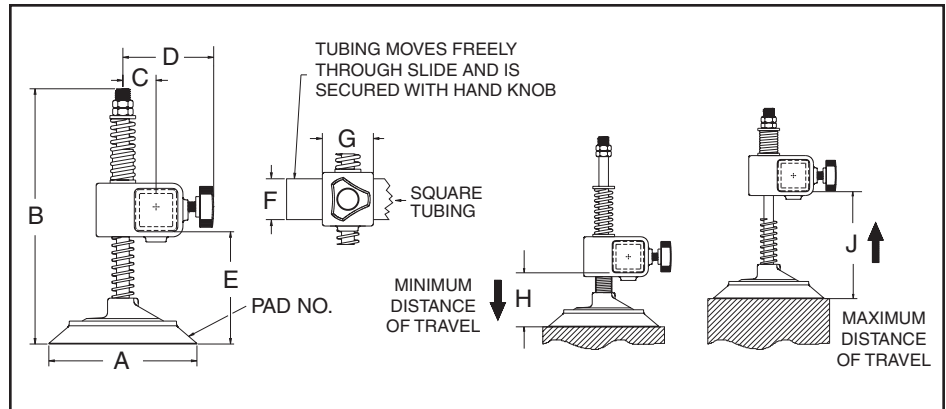

Features:

- Adjustable Slide Mounts
- For use with Medium, Side Port Vacuum Cups (VC Series)
- Designed for Rigid Cups

Susp. Model Number	A Cup Diameter in. (mm)	B in. (mm)	C in. (mm)	D in. (mm)	E in. (mm)	F Beam Size in. (mm)	G in. (mm)	H in. (mm)	J in. (mm)	Weight lb. (kg)	Capacity lb. (kg)*	Vacuum Pad Used
PS57R-NBR125	5.88 (149)	11.13 (283)	1.25 (32)	3.69 (94)	4.88 (124)	1.25 (32)	2.5 (64)	3.18 (81)	6.28 (160)	3.0 (1.4)	75 (34)	VC57
PS57R-NBR175	5.88 (149)	11.13 (283)	1.50 (38)	4.19 (106)	4.88 (124)	1.75 (44)	2.5 (64)	3.18 (81)	6.28 (160)	3.1 (1.4)	75 (34)	VC57
PS57R-NBR200	5.88 (149)	11.13 (283)	1.63 (41)	4.44 (113)	4.88 (124)	2.00 (51)	2.5 (64)	3.18 (81)	6.28 (160)	3.2 (1.5)	75 (34)	VC57
PS65R-NBR175	6.63 (168)	11.19 (284)	1.50 (38)	4.19 (106)	4.94 (125)	1.75 (44)	2.5 (64)	3.24 (82)	6.43 (163)	3.3 (1.5)	100 (45)	VC65
PS65R-NBR200	6.63 (168)	11.19 (284)	1.63 (41)	4.44 (113)	4.94 (125)	2.00 (51)	2.5 (64)	3.24 (82)	6.43 (163)	3.4 (1.5)	100 (45)	VC65
PS75R-NBR175	7.50 (191)	12.50 (318)	1.50 (38)	4.19 (106)	5.64 (143)	1.75 (44)	2.5 (64)	3.13 (80)	7.00 (178)	4.6 (2.1)	150 (68)	VC75
PS75R-NBR200	7.50 (191)	12.50 (318)	1.63 (41)	4.44 (113)	5.64 (143)	2.00 (51)	2.5 (64)	3.13 (80)	7.00 (178)	4.4 (2.0)	150 (68)	VC75
PS95R-NBR175	10.00 (254)	14.83 (377)	1.50 (38)	4.19 (106)	6.70 (170)	1.75 (44)	2.5 (64)	4.00 (102)	8.61 (219)	7.3 (3.3)	250 (113)	VC95R-2
PS95R-NBR200	10.00 (254)	14.83 (377)	1.63 (41)	4.44 (113)	6.70 (170)	2.00 (51)	2.5 (64)	4.00 (102)	8.61 (219)	7.2 (3.3)	250 (113)	VC95R-2
PS119R-NBR200	12.25 (311)	14.75 (3.75)	1.63 (41)	4.44 (113)	6.64 (169)	2.00 (51)	2.5 (64)	4.18 (106)	7.82 (199)	9.1 (4.1)	500 (227)	VC119R-2

* The cup capacities shown above are based on 24"Hg at sea level with a safety factor of two (2) in the horizontal (flat), and four (4) in the vertical (upright). Vertical Load Capacity is half of the listed Horizontal Load Capacities above.

Rated Load Capacities are estimated; actual capacity will vary based on the load surface and the level of vacuum.

➡ This spec sheet was adapted for print from our website. Additional information and photos are available at www.anver.com. 9041401