

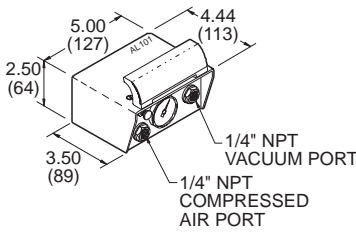

### ANVER AL101, AL1001/20 and AL1001/25 Series of Mini-Vacuum Stations

ANVER Air-Powered Mini-Vacuum Stations are low cost, compact, require little maintenance and feature quality ANVER venturi vacuum generators. A vacuum check valve maintains vacuum in case of power failure. On clean, smooth, non-porous material, the unit will hold vacuum per ASME Standard B30.20a-2001 for Vacuum Lifting Devices allowing the operator to put down the load safely. A vacuum release/blow-off valve ensures a quick and consistent attach and release for high production usage. Air supply must be clean, dry and regulated.

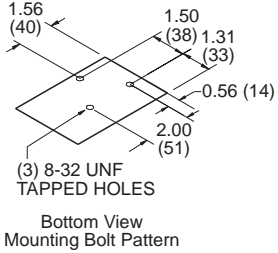

**AL101 Features:**  
Stainless Steel Enclosure and Plated Components



**AL1001 Features:**

- Include a pressure gauge for monitoring incoming compressed air
- These Mini-Vacuum Stations also perform well on slightly porous material
- An internal air filter with replaceable element on vacuum port protects against contamination

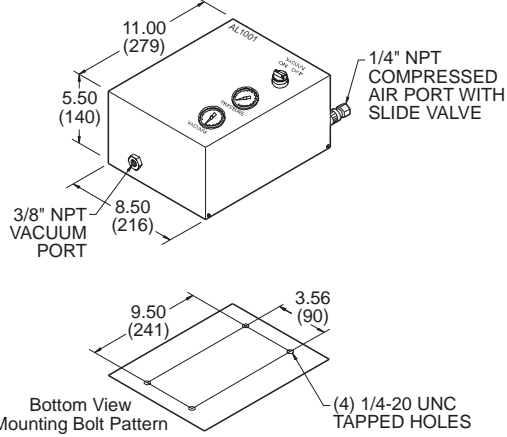

### Specifications:

ANVER Item No.	Vacuum Generator Model Number	Vacuum Flow SCFM (l/min.)	Air Consumption SCFM (l/min.)	Optimum Supply Pressure (PSI)	Maximum Vacuum in. Hg (mm Hg)	Weight lbs. (kg)
AL101	VR09	0.74 (21)	1.27 (36)	72.5	27 (686)	7 (3)
AL1001/20	JE20H	4.30 (122)	7.00 (198)	72.5	27 (686)	16 (7)
AL1001/25	JE25H	7.00 (198)	9.50 (269)	72.5	27 (686)	16 (7)