



VPF-57 AIR Series

ANVER's latest models of vacuum generators feature high capacity pumps, valves, filters and gauges for trouble-free operation in the most demanding production environments. Designed for use with a wide assortment of vacuum lifter assemblies and interchangeable pad attachments. These high quality Vac-Packs are ruggedly built, yet affordably priced for unmatched value. The VPF-57 AIR Series features a sturdy welded frame construction for heavy weight load lifting capability.

Features:

- Air Powered Vacuum Generator**
 No electric power required, operates using dry, clean compressed air for vacuum generation. The vacuum generator is a single stage unit with no moving parts or rubber gaskets to maintain or replace.
- Front Mounted Gauges**
 Includes both an input air pressure and vacuum indicator gauges, front mounted for continuous monitoring by the operator. Also included is a filter view port to monitor filter for cleaning.
- Ergonomic Adjustable Front Handlebar**
 Easy to grasp, large loop handlebar enables the operator to easily and safely maneuver the attached load without touching the load itself. Handlebar can be adjusted for smaller loads.
- Slide Control Valve with Standard Safety Lock**
 The slide valve assembly allows vacuum attach and release and is mounted to the front handlebar for convenient access by the operator. The standard safety lock is to keep the slide valve in the attach position while lifting a load to prevent accidental load release.
- Vacuum Check Valve and Reservoir**
 A check valve and a vacuum reservoir help to maintain vacuum if the supply of compressed air is interrupted, for safe handling of non-porous loads.
- Takes Standard Dry, Clean Shop Air**
 Input Pressure to be regulated to 72.5 psi. Provided with 1/4" NPT input air supply connector and shut-off slide valve.
- Vacuum Leakage Sensing System (VLS-08 & VLS-08-20)**
 The VLS-08 (Series) are battery powered units consisting of solid state circuitry with microprocessor, pressure sensor, LCD digital display in inches of Hg, warning audible horn and red light. System is plumbed to the Vac-Pack and monitors vacuum level triggering the alarm in the event of a loss in vacuum level (10% loss for VLS-08 / 20% loss for VLS-08-20).

Maintenance:

- Air Filter**
 High capacity air filter provides protection against pump damage. It is mounted behind the front cover which has a view port for routine inspection.

General:

- Frame Construction**
 The VPF-57-AIR Series has a fully welded frame with a vacuum reservoir and a lifting bale and beam mounting hardware.
 - Standard for 3"x3" beam [9" hardware centers] with a structural lifting capacity rating up to 2,200 lbs (998 kg).
 - Heavy Duty for 3"x6" beam [9" hardware centers] and reinforced lifting bale with a structural lifting capacity rating up to 4,400 lbs (1,996 kg).
- Versatility**
 For larger load lifting capability or alternate power requirements, ANVER offers electric powered and self-powered mechanical vacuum generators, all with standard mounting designs for interchangeability.

Options:

- Optional Moisture Trap (WT-PF)**
 For damp applications: prevents moisture saturation of filter and possible damage to pump. Not for handling wet loads.

Meets American National Standard ASME B30.20-2006 specifications for Below-the-Hook Lifting Devices. Please refer to Chapter 20-2.

Specifications: *Generator part number suffix may be different than shown to suit application requirements.

Vac-Pack Series*	Vacuum Flow (scfm)	Air Consumption (scfm)	Optimum In. Pressure (psi)**	Unit Weight lb. (Kg)	Vacuum Level (Sea Level)	Application	Vac-Pack Frame		
							Classification	Beam Size	
VPF-57/20-AIR (Standard)	4.3	6.5	72.5	56 (25.4)	24" Hg	Most smooth, non-porous materials	Standard	3" Sq.	
VPF-57/30-AIR	9.2	14.0			Consult Factory				Rough or semi-porous materials, wood, stone, etc.
VPF-57/MSP100-AIR	31.7	13.4			Consult Factory				
VPF-57/20HD-AIR	4.3	6.5	72.5	60 (27.2)	24" Hg	Most smooth, non-porous materials	Heavy Duty	3" x 6"	
VPF-57/30HD-AIR	9.2	14.0			Consult Factory				Rough or semi-porous materials, wood, stone, etc.
VPF-57/MSP100HD-AIR	31.7	13.4			Consult Factory				



WARNING ** Air supply flow (CFM) may adversely affect required pressure (psi) to achieve optimum vacuum level.

VPF-57 AIR Series

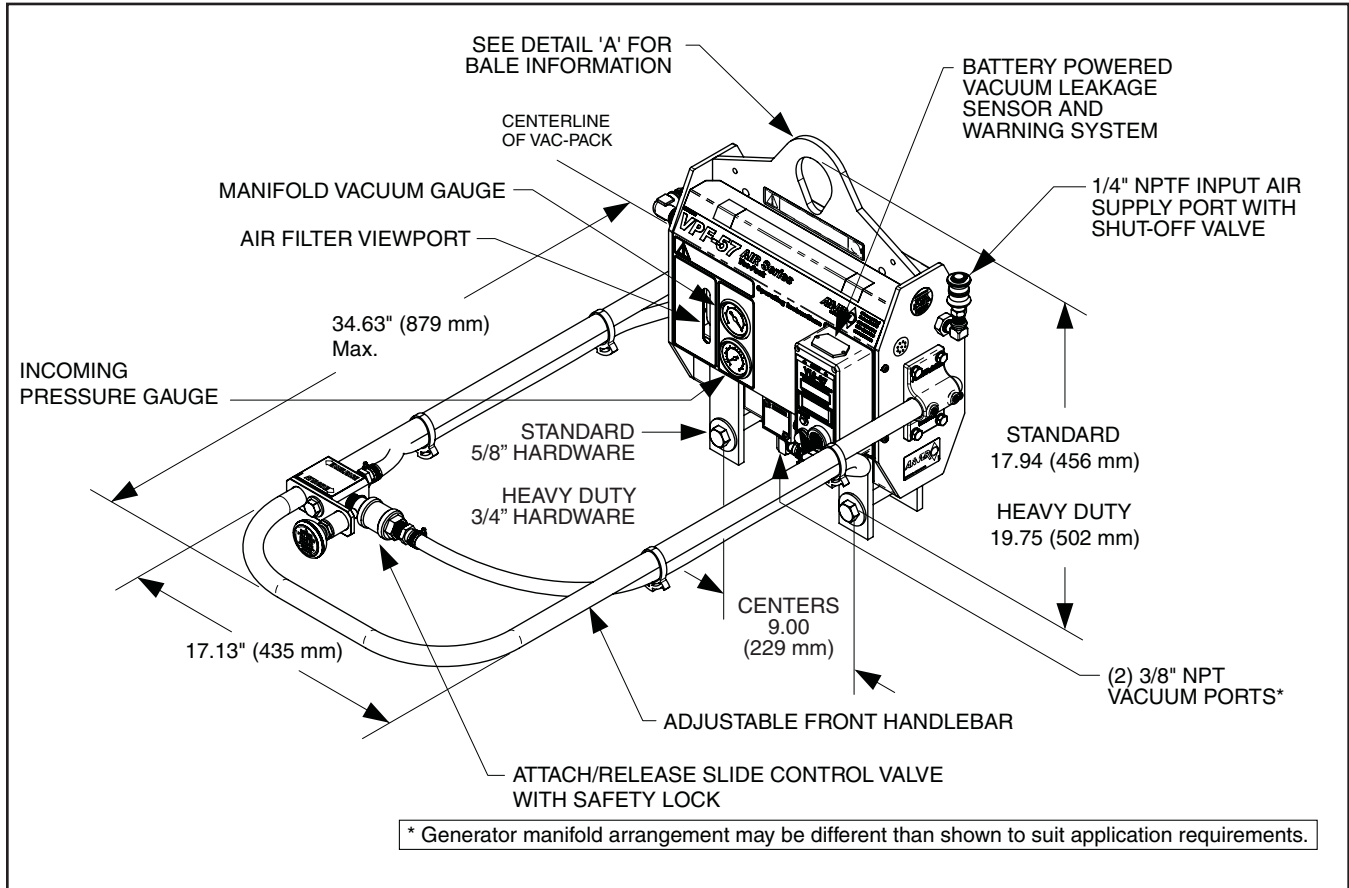

**DETAIL 'A'
BALE INFORMATION**

