

Features:

- Oil free
- Maintenance free
- Operates quietly-maximum 70 dB (A)
- Cooler running outboard bearings increase service life
- Built-in particulate filters and silencers
- Compact lightweight design
- Handles vacuum and/or pressure applications
- Ideal alternative to standard oil sealed rotary vane pumps

Performance Curves: 60Hz

Vacuum

in. Hg

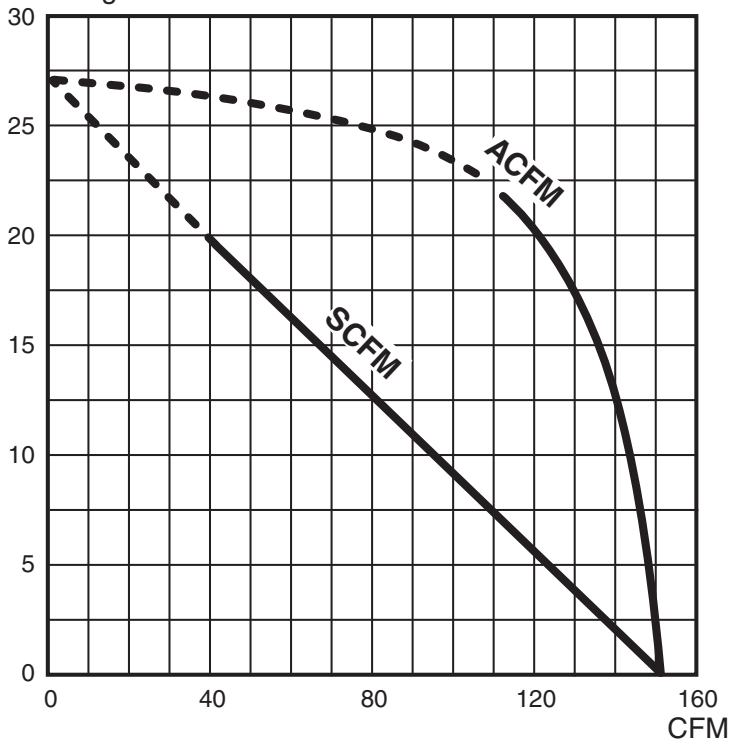

Vacuum Pumps and Vacuum Generators



Dry Rotary Vane Vacuum Pumps / PMP-150

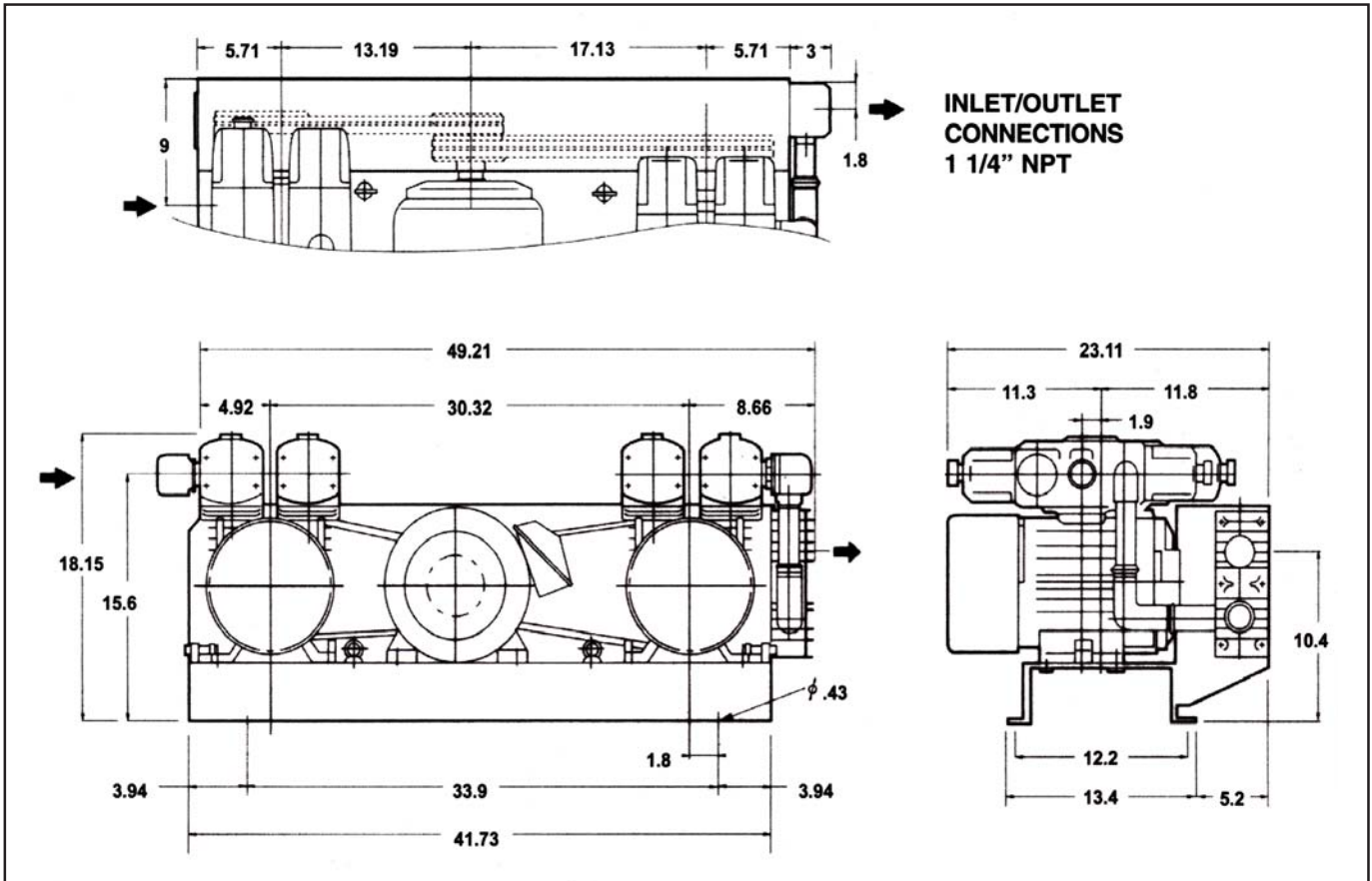

Vacuum Specifications

Motor	RPM	Motor HP (Kw)	Vacuum Flow (CFM)	Max. in. Hg	lb (kg)
w/o motor	-	-	150	27.5"	450 (205)
208-230/460V	1200	10	150	27.5"	522 (237)

NOTES:

- a. Standard voltage for three phase pump is 208-230/460V/3ph 60Hz.
- b. Standard voltage for single phase pump is 115/230/1ph 50/60Hz or 115V/1ph 60Hz or 230V/1ph 60Hz.
- c. All pumps available in 50Hz frequency, and with other voltages. Contact Factory for more information.